

1.View and size(视图及尺寸)

Main technical indicators(主要技术指标)	
1.Mating (插拔次数)	5000
2.Working Temperature (温度)	-55~+150 ℃
3.IP Rating (防护级别)	IP 50
4.Diameter of socket end(插合端直径)	φ1.3MM
5.Vtest (AC) /测试电压(交流)	1200V
6.Vtest (DC) /测试电压(直流)	1800V
7.Rated Current (额定电流)	15A
8.Shell material(壳体材质)	Brass (chrome plated) shell and collet nut, nickel plated brass latch sleeve and mid pieces /黄铜（镀铬）外壳和夹头螺母，镀镍黄铜锁套和中间件
9.Pin Material(插针材料)	Copper alloy gold plating(铜合金镀金)
10.Insulator material(绝缘体材质)	PPS

Sum up(总结)	
Series(系列)	S
Shell style/model (外壳样式/型号)	TLA: Elbow plug, cable collet/弯头插头、电缆夹头
Button (按键)	Hermaphroditic keying (half moon insert) with male pin 1/带公销1的公母键控（半月形插入）
Termination type (终止类型)	Male solder(公焊锡)
Line diameter awg(线材直径)	28AWG-20AWG
Cable diameterφ (电缆直径)	φ5.3-6.2MM
Matching parts(配套零件)	ZRA.1S.P02.CLL

Sum up(总结)	
Humidity (max)/湿度最大	<=95% [at 60 deg C /140 F] / <=95%[在60摄氏度/140摄氏度时]
Vibration/震动	15g [10 Hz - 2000 Hz]
Shock Resistance/抗冲击性	100 g [6 ms]
Climatical Category /气候类别	50/175/21
Salt Spray Corrosion/盐雾测试	>48 hr />48小时

	A	B	C√	ANGLE	
5-10	±0.02	±0.05	±0.1	0°-30°	±0.1°
50-100	±0.1	±0.15	±0.2	61°-90°	±0.5°
50-100	±0.15	±0.2	±0.25		
100-	±0.15%	±0.20%	±0.25%		

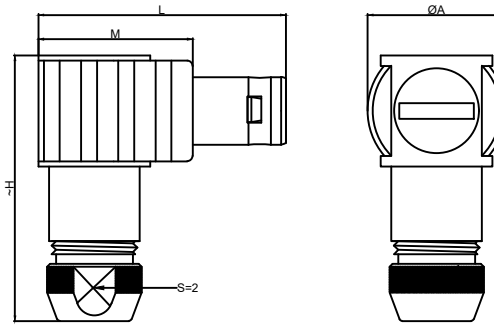

	A	L	M	H	S2
MM	16	26.5	15.5	28.5	8.5
in	0.63	1.04	0.61	1.12	0.33

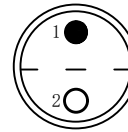

Welded surface
(焊接面)



Solder core
(焊接型公胶芯)

TLA. 1S. P02.C L A C 62

Model(型号)

Series(系列)

Needle core configuration(针芯配置)

Outer casing(外壳)

Insulator(绝缘体)

Needle core(针芯)

Type of clamp(线夹类型)

Cable diameter(电缆直径)

DESIGNED (设计)		DATE(日期)		SCALE(比例)	N/A(不适用)	MODEL TYPE 型号类型: TLA.1S.P02.CLAC.62
CHECKED (校对)		DATE(日期)		VIEW(视图)		PART NO. 1S2-core plug 名称: 1S2芯插头
APPROVED (审核)		DATE(日期)		UNIT(单位)	MM	DWG NO.:
REVISIONS				MATERIAL (材料)		
www.helloxkb.com www.helloxkb.cn			XKB INDUSTRIAL PRECISION CO.,LIMITED			WEIGHT(重量) SHEET(表) REVISION(修订) 1/1 A0